

VBOX CAN Gateway (RLVBCGW01)



The VBOX CAN Gateway is designed to control flow of CAN data between two separate buses. It allows logging of vehicle CAN or CAN FD bus data to a VBOX system while simultaneously allowing secondary CAN modules such as the Mini input module to communicate with the VBOX.

Under normal circumstances, attempting to capture CAN data from a car as well as that from a module would lead to VBOX and VBOX Module data being put into the vehicle CAN Bus – with unpredictable and almost certainly unwanted results. The CAN Gateway allows for both data streams to be logged by the VBOX without any of the module traffic going back onto the vehicle Bus.



When connected to a PC via the supplied USB cable (RLCAB117), the CAN Interface can be programmed using dedicated setup software to read almost any CAN or CAN FD format message and be configured to then re-transmit them onto the VBOX CAN bus.

Features

- Allows the conversion of CAN FD messages to CAN suitable for use with VBOX products
- Simple configuration software
- 125 Kbit, 250 Kbit, 500 Kbit and 1 Mbit CAN rates and up to 4 MB data rates for CAN FD
- Isolates VBOX data from vehicle CAN bus
- Input up to 32 CAN or CAN FD data channels from vehicle or another CAN bus
- Output 32 CAN data Channels to VBOX

Module Connection Example

CAN Gateway can be connected to a VBOX 3i via an RLCAB006 cable (included in package) in order to record data from a vehicle CAN Bus and a Racelogic module at the same time.

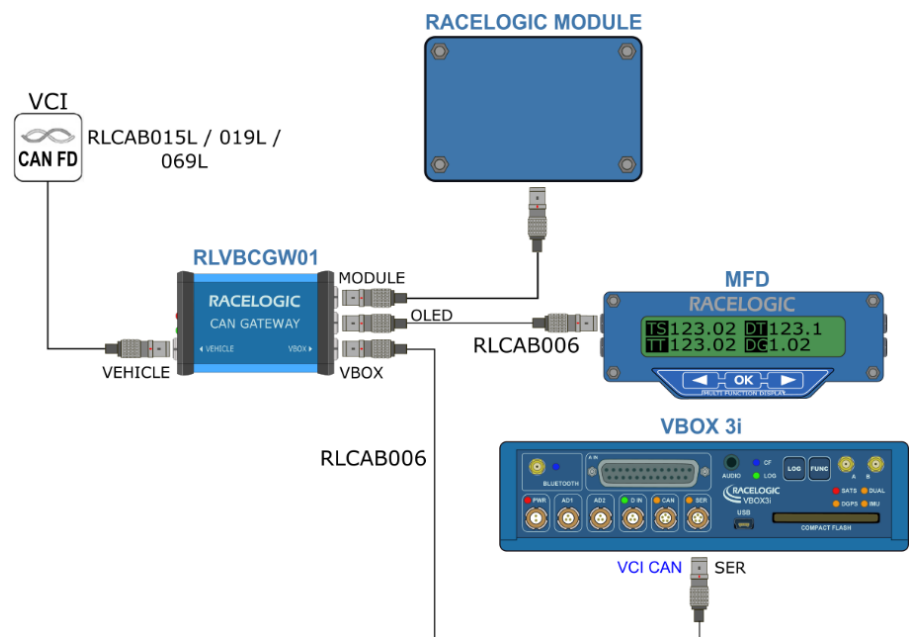

VBOX CAN Gateway (RLVBCGW01)



Inputs / Outputs



| Connection | Function |
|----------------------|---|
| CAN A Vehicle | CAN or CAN FD Data is captured and transferred to CAN B output for logging. |
| CAN B OLED | Connection for the RLVBDSPO3-24 Multi-Function Display. |
| CAN B Module | Connection to input module. For example, RLVBIM01 Mini Input Module or RLVBICIN01 Micro Input Module. |
| CAN B VBOX | Connection to VBOX VB3i CAN Bus. |
| USB | Configuration via PC. When connected to a PC via the supplied RLCAB117 USB cable, CAN Gateway will be powered and will appear as a USB drive. |

VBOX CAN Gateway (RLVBCGW01)



PIN Allocation

| Vehicle Connector | | |
|-------------------|-----|------------------|
| Pin | I/O | Function |
| 1 | O | Rx-RS232 (1) |
| 2 | I | Tx-RS232 (1) |
| 3 | I/O | CAN High (CAN A) |
| 4 | I/O | CAN Low (CAN A) |
| 5 | O | Power |

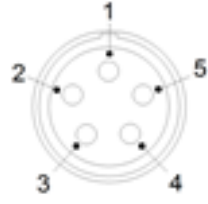

| VBOX Connector | | |
|----------------|-----|-------------------------|
| Pin | I/O | Function |
| 1 | O | Rx-RS232 (Pass-through) |
| 2 | I | Tx-RS232 (Pass-through) |
| 3 | I/O | CAN High (CAN B) |
| 4 | I/O | CAN Low (CAN B) |
| 5 | O | Power |

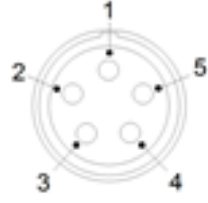

| OLED Connector | | |
|----------------|-----|-------------------------|
| Pin | I/O | Function |
| 1 | O | Rx-RS232 (Pass-through) |
| 2 | I | Tx-RS232 (Pass-through) |
| 3 | I/O | CAN High (CAN B) |
| 4 | I/O | CAN Low (CAN B) |
| 5 | O | Power |

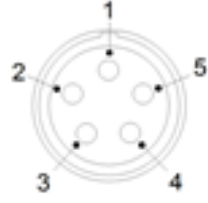

| Module Connector | | |
|------------------|-----|------------------|
| Pin | I/O | Function |
| 1 | O | Rx-RS232 (2) |
| 2 | I | Tx-RS232 (2) |
| 3 | I/O | CAN High (CAN B) |
| 4 | I/O | CAN Low (CAN B) |
| 5 | O | Power |

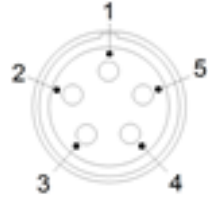

VBOX CAN Gateway (RLVBCGW01)



Environmental and Physical

| | |
|-----------------------|---|
| Operating Temperature | -20°C to +70°C |
| Storage Temperature | -40°C to +85°C |
| Input Voltage | 4.5 - 30 V DC |
| Power | 0.6 W |
| Weight | 110g |
| Dimensions | L 90.8 mm (3.57") W 57.13 mm (2.26") H 26.13 mm (1.03") |
| Protection Rating | IP 51 |

Package Contents

| Description | Product Code |
|---------------------------------------|--------------|
| 1x CAN Gateway module | VBCGW01 |
| 1x VBOX to VBOX Module cable (30 cm) | RLCAB006 |
| 1x USB 'A' to Micro 'B' cable (1.8 m) | RLCAB117 |

Optional cable to connect to a vehicle CAN bus:

- Unterminated CAN cable (RLCAB015L)
- Lemo 5W plug - 9W D Socket CAN cable (RLCAB019L)
- OBD CAN cable (RLCAB069L) -
If CAN is available on the OBD connector

